

WORKING PAPER 2015

The role of liquidity preference in a framework of endogenous money

Marco Missaglia and Alberto Botta

July 2020



The role of liquidity preference in a framework of endogenous money

Marco Missaglia, University of Pavia, Italy*

Alberto Botta, University of Greenwich, United Kingdom**

Abstract: In this paper we build a simple, almost pedagogical, Keynesian model about the role of liquidity preference in the determination of economic performance. We assume a world of endogenous money, where the banking system is able to fix the interest rate at a level of its own willing. Even in this framework, we show that the Keynesian theory of liquidity preference, while obviously not constituting anymore a theory for the determination of the interest rate, continues to be a fundamental piece of theory for the determination of the level and evolution of aggregate income over time, both in the short and in the medium run. However powerful, the banking system and monetary authorities are not the *deus ex-machina* of our economies and financial markets are likely to exert a permanent influence on our economic destiny.

Key words: Liquidity preference, endogenous money, finance dominance

JEL code: C62, E12, E44

1. Introduction

The theory of liquidity preference developed by Keynes in the General Theory was, at the same time, a theory for the determination of the interest rate and a theory for the determination of the level of activity. As is well known, this theory was developed in a framework of exogenous money. Money supply was taken as fixed, decided by monetary authorities, and fluctuations of money demand were in charge of determining the equilibrium interest rate and *then* the level of output. This is essentially the traditional IS-LM scheme all of us grew up with. Money, however, is endogenous. The monetary authority (*or, latu sensu*, the banking system) does not decide the quantity of money, but the interest rate. This is now recognized even by the many (the large majority of the profession) who still adhere to the Wicksellian loanable funds theory and believe in the existence of a natural interest rate

* Department of Political and Social Sciences, University of Pavia. Email: marco.missaglia@unipv.it.

** Department of Economics and International Business, Business School, University of Greenwich. Email: A.botta@greenwich.ac.uk.

determined by the fundamentals of thrift and productivity. The central bank decides the policy rate and allows the supply of money to adjust to whatever is the level of demand.

Does money endogeneity imply that the Keynesian theory of liquidity preference becomes a useless tool? Some strands of Keynesianism seem to share the same, positive answer. Take for instance the so-called New Consensus. Carlin and Soskice (2015), who made a great effort to spread and clarify the neo-Keynesian perspective by means of very elegant and accessible models, are very explicit:

“... structural changes in the economy that shift the private sector’s demand for money, do not alter the central bank’s ability to achieve its desired output gap... any shift in the money demand function affects the money supply [endogenous money] but does not feedback to influence real economic activity” (pp. 158-159).

In a very useful representation of the New Consensus 3-equation model, Lavoie (2009) shows things are a bit more complicated. A rise in liquidity preference, there represented as a “Minsky moment” (a rush towards liquidity and riskless assets that prompts an increase in those market rates relevant to the private sector’s spending decisions), does have a temporary recessionary impact. However, if the central bank is able to revise downward its estimate of the natural interest rate and reduces the policy rate accordingly (which is not to be taken for granted, since market rates are on the rise), the economy will return at its NAIRU equilibrium and inflation on target. A variation in liquidity preference, despite its real short-term effects, does not modify the steady-state position of the economy¹.

Post-Keynesian authors do not have a unique position in this respect. Some authors, the so-called “early horizontalists”² (for instance Moore, 1988), believe in the ability of the banking system to fix the interest rate at a level of its own willing and follow Kaldor (1985) in denying any significant role to liquidity preference:

“... ‘liquidity preference’ was regarded as the essential factor that distinguished Keynesian from pre-Keynesian theories.... All this, however, depended on the assumption of the quantity of money being determined irrespective of all other factors that determined the demand for goods and services. If we regard money as an endogenous factor, *liquidity preference and the assumption of interest-elasticity of the demand for money cease to be of any importance*” (p.9; italics is ours).

Quite an astonishing parabola: from being the cornerstone of the Keynesian edifice (“the essential factor that distinguished Keynesian from pre-Keynesian theories”), liquidity preference “ceases to be of any importance”. This horizontalist perspective was also

¹ Of course, the real effects of liquidity preference variations would be permanent in a model with growth hysteresis (due, for instance, to some kind of Kaldorian technical progress function). However, this would be true for any possible shock and not just for liquidity preference shifts.

² This terminology is due to Palley (2017).

incorporated in an important post-Keynesian pedagogical model proposed by Fontana and Setterfield (2009): an attempt at building a simple and teachable model (to be compared with the 3-equation model of the neo-Keynesians, the IS-LM, etc.) to spread and popularize post-Keynesian ideas.

Other authors, the so-called “structuralist” (Palley, 1994, 2013, 2017; Dow, 1997), believe that banks’ behavior is characterized by a traditional upward sloping loans’ supply curve - the interest rate goes up with credit expansion and constitutes an endogenous variable of the system. In this case, money is endogenous but the liquidity preference of the public may matter again. As it was the case in the General Theory, it might constitute a key parameter in the determination of the interest rate and the level of economic activity³:

“An increase in liquidity preference puts upward pressure on interest rates, which in turn puts downward pressure on output and employment, as long as the money supply is constrained to some degree” (Dow, 1997, p.64)

This debate is very important not only for its analytical and theoretical implications, but also for political reasons. At the end of the day, it is a debate around the relative roles of and distribution of power between central banks and financial markets – horizontalists (and their modern followers of the Modern Monetary Theory) give prominence to the power of monetary authorities, structuralists recognize a crucial macroeconomic role for financial markets (of which commercial banks are now integral part), “money managers” and the alike. In a sense, the Keynesian theory of liquidity preference was a recognition of the power of the City, of how its changing mood and orientations could seriously affect the real economy and the concrete prospects of firms and households. Nowadays, even the neo-mercantilist struggle taking place in the world economy can be read as a manifestation of the liquidity preference issue: everyone wants to sell, no one wants to spend, and this is obviously impossible to achieve. This is for instance the interpretation offered by Bibow (2009) in his important and authoritative book on the Keynesian theory of liquidity preference, viewed as the fundamental piece of economic theory needed to understand the big mess in global finance that led to and accompanied the 2007-8 world crisis.

It is not surprising, then, that some recent papers – Oreiro et.al. (2020), Mehrling (2020), Bertocco and Kalajzic (2014 and 2018), Dafermos (2012), Lavoie and Reissl (2018), Palley (2017) and Asensio (2017) among others – have revived this important debate around the macroeconomic role of the Keynesian theory of liquidity preference in a world of endogenous money. The purpose of this paper is to add to this debate by making it clear an important point which is somewhat obscured by the *querelle* between horizontalists and structuralists: *liquidity preference does not have to affect the interest rate in order to be an important determinant of the level of activity*. One could easily imagine an economy where the interest

³ According to Palley (2017), there are also “later horizontalists” (for instance Lavoie, 2006). These authors fully acknowledge the role of liquidity preference in the determination of interest rates, but do not recognize that the overall financial system may be “financially constrained”.

rate is fully exogenous (a “horizontalist environment”, so to speak) and, yet, fluctuations in money demand continue to play a crucial role in the determination of the real equilibrium of the economy. There is more than that. We will see that the case where liquidity preference “ceases to be of any importance” - what we are going to label the “Kaldorian view” - is a very special one, whereas the general case is one where, while not constituting a theory for the determination of the interest rate anymore, the theory of liquidity preference continues to be, both in the short- and in the medium-run, a (fundamental piece of a) theory for the determination of aggregate income.

2. Wealth accounting

In many instances, the recent debate on the macroeconomic role of liquidity preference does not consider exclusively the liquidity preference of the public (households’ liquidity preference), but also the liquidity preference of banks and other financial firms. This certainly helps and constitutes an element of realism in any applied macro model. The route we are going to follow here, however, is different. We will show, with the ambition to offer some theoretical insights and possibly a useful pedagogical tool, that the very simple structure of the traditional Keynesian textbook model (or even a somewhat simpler structure, just a bit more than the Keynesian cross) is more than enough to understand the reasons why the liquidity preference of the general public continues to represent, even in a world of endogenous money, a key determinant of the steady state (medium run⁴) level of real output. So, in the economy we are going to study, closed to the rest of the world, there are households, non-financial firms (or simply firms) and banks. There is no government, and there is no need to think of a central bank, i.e. a monetary authority in charge of printing a legal tender or, in any case, a piece of paper generally accepted as a means of payment. The economy produces one commodity, GDP, used for both consumption and investment purposes and its price is fixed at 1 (putting inflation into the picture would not change our point). For the sake of the argument, we will assume that firms do not retain profits (their wealth is zero) and then have to make recourse to external finance to fund capital accumulation (including retained profits would not change the logic of our argument, except in the completely unrealistic case where this is the only way of financing capital accumulation). Banks and households may provide this finance:

“The transition from a lower to a higher scale of activity involves an increased demand for liquid resources which cannot be met without a rise in the rate of interest, unless the banks are ready to lend more cash or the rest of the public to release more cash at the existing rate of interest” (Keynes, 1937, p.222).

⁴ In this paper we will not employ the expression “long run” in association with the steady state equilibrium of the system. The reason is that labor productivity (technology) and population (labor force) will be taken as fixed: the time horizon we are taking into consideration is not “long” enough to allow these magnitudes to vary.

The banking system creates money (M) by extending loans (L) - “loans make deposits”, according to the endogenous money *adagio*. Households (“the rest of the public”) cannot create money ex-nihilo and make loans to firms by subscribing bonds (“releasing more cash”), B, i.e. by changing the composition of their wealth (less money, more bonds). We will assume that bonds are “consols” or perpetuities. These are pieces of paper which are never redeemed and pay the owners, say, 1 dollar after one period has elapsed. The market price of these bonds is p_b and by construction the interest rate on them is $i_b = 1/p_b$, with $p_b = 1 + 1/(1+i_b) + 1/(1+i_b)^2 + \dots = 1/i_b$. The above assumptions (and some others we are going to discuss) are incorporated in tables 1 and 2. Whilst Table 1 shows the balance sheet of the economy, i.e., the stock of assets and liabilities held by the different institutional sectors, Table 2 reports the ensuing flow of funds:

[TABLES 1 AND 2 ABOUT HERE]

In each moment in time households’ wealth is:

$$V_h = M + \frac{B}{i_b},$$

and then evolves over time according to (as usual a “dot” over a variable indicates its time derivative, whereas a “hat” stands for its growth rate)

$$\dot{V}_h = \left(\dot{M} + \frac{\dot{B}}{i_b} \right) - \hat{i}_b \frac{B}{i_b} \quad (1)$$

In words: households’ wealth increases because of savings (the term in parenthesis) and capital gains/losses (a reduction in the interest rate is the same as an increase in the price of bonds).

Firms’ net worth is defined as

$$V_F = K - L - \frac{B}{i_b},$$

and, denoting with “I” aggregate investments, evolves according to

$$\dot{V}_F = I - \left(\dot{L} + \frac{\dot{B}}{i_b} \right) + \hat{i}_b \frac{B}{i_b}$$

Since we are assuming that firms’ profits are fully distributed and investments are to be funded by making recourse to external sources – bonds and banks’ loans (the term in parenthesis) – the previous expression simplifies to

$$\dot{V}_F = \hat{i}_b \frac{B}{i_b} \quad (2)$$

Comparing the variations of households’ and firms’ net worth – expressions (1) and (2) - it is clear (and obvious) that when the interest rate on bonds goes down (the price of bonds goes up) households become richer and firms correspondingly poorer, and vice versa (this can be

seen also from the last, “memo” row of Table 2). Net worth moves from the pockets of firms (households) to those of households (firms). Now, depending on the purpose of the analysis, one could decide to abstract from these capital gains/losses and the implied redistributive effect we just mentioned. This is exactly what we are going to do here. This does not mean we take the interest rate as irrevocably fixed – in this world of endogenous money, banks may always decide to fix the interest rate at whatever level they judge to be appropriate. It just means we abstract from the redistributive effect produced by its variations. And, in any case, the idea of the present study is exactly to understand the real effect of different degrees of liquidity preference *for given levels of the interest rate*. Hence, abstracting from capital gains, we will work with:

$$\dot{V}_h = \left(\dot{M} + \frac{\dot{B}}{i_b} \right) \text{ and } V_F = \dot{V}_F = 0 \quad (3)$$

What about banks’ net worth? This is an important point, since as we shall see different assumptions (implicit or explicit) on banks’ behavior and net worth are associated to different views on the macroeconomic role of households’ liquidity preference. Banks’ net worth is defined as

$$V_b = L - M$$

Call “ i_L ” the interest rate on bank loans and assume banks do not pay any interest on deposits. If a fraction $0 \leq \lambda \leq 1$ of their profits is distributed to households (a point we will discuss at length in section 4), their wealth evolves according to⁵

$$\dot{V}_b = \dot{L} - \dot{M} = (1 - \lambda)i_L L \quad (4)$$

It might be observed that equation (4) says that the sum of the banks’ capital account column in Table 2 is zero. In case banks’ profits are fully distributed ($\lambda = 1$):

$$V_b = \dot{V}_b = 0 \quad (5)$$

We are now ready to illustrate the Kaldorian view - liquidity preference does not play any significant role and “ceases to be of any importance”.

3. The Kaldorian view

Assumptions (3) and (5) greatly simplify the analysis and make it possible to think of an economy where

$$V_H + V_F + V_B = V_H = K \quad (6)$$

⁵ See Appendix 1 for some further clarification on the meaning and derivation of equation (4).

In this model economy, output (Y) is determined by aggregate demand, consumption (C) plus investments (I):

$$Y = C + I$$

Normalizing by the capital stock and defining $u = Y/K$ (a proxy for capacity utilization), $c = C/K$ (normalized consumption) and $g = I/K$ (the rate of capital accumulation), we get:

$$u = c + g \tag{7}$$

As it is the case in several Keynesian models, aggregate consumption is postulated to be a positive function of households' current income and accumulated wealth (this can be easily derived from a Modigliani (1986) aggregate consumption function). Given our assumptions – in particular: firms' and banks' profits are fully distributed – households' income is here the same as GDP and, using a linear form, we may then write:

$$C = \alpha Y + \beta V_h$$

Normalizing again by the capital stock and using (6), this becomes:

$$c = \alpha u + \beta \tag{8}$$

The good way to write an investment function is a controversial issue within the Keynesian tradition. In fairly general terms, investment spending is likely to respond positively to the (expected) profit rate. In the simple economy we are dealing with, the net macro profit rate accruing to non-financial firms is to be calculated as

$$r = \frac{Y - W - i_L L - i_B (B/i_B)}{K} = \frac{Y - W - i_L L - B}{K}$$

where W is the wage bill paid by firms to households and interest payments have been accounted for in the calculation of net profits. Be $W/K = \omega N/K = \omega(N/Y)(Y/K) = \omega a(Y/K)$, with “ N ” indicating total employment, “ ω ” the wage rate (real and nominal, there is no difference here) and “ a ” representing the labor coefficient (the inverse of labor productivity). Assuming $a = 1$ (we are not interested in studying the dynamics of labor productivity), we have $W/K = \omega(Y/K)$, with ω representing at the same time the wage rate and the wage share in total GDP. Then, defining $l = L/K$ (this is the share of capital accumulation financed through bank loans) and observing that (3) implies $L/K + i_b(B/(i_b K)) = 1$, we may express the profit rate as

$$r = (1 - \omega)u - [i_L l + i_b(1 - l)]$$

If, from the perspective of non-financial firms, bonds and bank loans are perfect substitutes (another crucial assumption in the discourse on liquidity preference) and one is not ready to accept corner solutions, it must be $i_b = i_L = i$. Hence,

$$r = (1 - \omega)u - i \tag{9}$$

There are different ways of mixing the components of the net macro profit rate included in (9) – distribution (ω), demand (u) and finance (i) – to cook some kind of Keynesian investment function. Here, for the sake of the argument, we want to keep the investment function as simple as possible and only concentrate on the accelerator term (including the interest rate as a specific argument of the investment function would make the model more complicated without affecting the role of liquidity preference in this economy):

$$g = \gamma + \delta u \quad (10)$$

Equations (7), (8) and (10) constitute a complete model for the determination of the flow-equilibrium of the economy. This model (nothing but the Keynesian cross) fully determines the three endogenous variables u , c and g . What about the financial (stock) side of the economy? How are the composition of households' wealth (bonds, money) and the composition of firms' financing (bonds, loans) determined? Assume the economy is in a steady-state: period after period, each flow and each stock of this economy grow at the rate g determined by the system (7)-(8)-(10). This clearly implies that in such a steady state the shares of money and bonds in households' portfolios and the shares of firms' investments funded by bonds and bank loans are constant. The interest rate is constant as well. At a point, for whatever reason (a sunspot), liquidity preference goes up. People stop subscribing bonds at the same rhythm as before and banks – in order to prevent the interest rate from increasing – expand their supply of loans (and then money supply: loans make deposits). Banks are giving households the extra-money they want to hold (money supply adjusts to money demand) and are giving firms the amount of funds that households do not want to lend anymore. The share of firms' investment funded by bank loans and the share of money in households' portfolios increase, but the real equilibrium is totally unaffected. To go back to Keynes' quotation, this is nothing but a model where in case "the public decides to release less cash", "banks are ready to lend more". No more than that.

This result of irrelevance of liquidity preference rests essentially on three key assumptions: 1) capital gains/losses are assumed away; 2) banks' profits are fully distributed to households; 3) bonds and bank loans are treated as perfect substitutes from the perspective of non-financial firms. Removing either the first or the second or the third assumption is more than enough to reconstitute liquidity preference a key role in the determination of aggregate income in a world of endogenous money. Taking capital gains into consideration would force us to recognize that households' wealth and its evolution over time (and then aggregate consumption, aggregate demand and output) do not depend exclusively on households' overall savings, but also on how these savings are allocated between money and bonds, since the latter is the only item on which capital gains (losses) may mature. Considering bank loans and corporate bonds as imperfect substitutes would force us to recognize that the profit rate realized by non-financial firms (and then capital accumulation) depends on the willingness of the public "to release more or less cash". In this paper, however, we shall not elaborate on these possibilities and maintain assumptions 1) and 3). We rather study the implications of removing the second assumption – full distribution of banks' profits.

4. Being a banker is costly

4.1 *The short run*

In the scheme we proposed so far, banks make profits out of nothing, out of their privilege to create money *ex-nihilo*. A banker is then a *rentier*, i.e. a social actor that can eat a portion of the cake without contributing to cook it. In most cases, however, the privilege that defines the status of a *rentier* is not indefinitely granted for free. A landlord who is making money by renting her land must spend some money from time to time to keep her plot in decent conditions, otherwise she would sooner or later become unable to rent it out and would lose her privilege. The banker is no exception⁶. Her privilege comes from the possibility of having her liabilities accepted as means of payments, since no one would get a loan from a bank whose liabilities are not generally accepted as means of payment, and as a consequence that bank would lose the possibility to make loans and earn profits in the first place. It would not be a bank anymore. Well, the only reasonable way to have own liabilities accepted as means of payment is to dispose of a sufficient amount of own funds and, needless to say, own funds must grow somewhat proportionately to the stock of liabilities. This is the rationale behind those regulations imposing banks to respect some minimum “capital adequacy ratio”. And in any case, even without those regulations, banks would have an incentive to accumulate own funds, otherwise – sooner or later – they would go bankruptcy and the banker would lose the privilege of being a *rentier*. These simple and obvious observations are more than enough to recognize the important role of households’ liquidity preference in a world of endogenous money. Let us see why.

Assume banks only distribute a fraction $0 < \lambda < 1$ of their profits, and the rest is devoted to the accumulation of own funds. The evolution of banks’ wealth is then described by (4) and is fully determined by the fraction of retained profits. Equations (7) and (10) remain the same as before, but the consumption function (8) is to be amended. First, there is no coincidence now between GDP (Y) and households’ income, since households are not receiving the totality of banks’ profits anymore (this is clear from Table 2). Second, even if we keep assuming that $V_F = 0$ (and we do), the very fact that households’ do not receive the totality of banks’ profits (and then $V_b > 0$) implies that their wealth does not coincide anymore with the capital stock of the economy, and we now have $V_H = K - V_b$. If we maintain that aggregate consumption is a function of households’ income and wealth, the relevant equation becomes:

$$c = \alpha[u - (1 - \lambda)il] + \beta v_H \quad (11)$$

having defined $v_H = V_H/K$, the fraction of national wealth in the hands of households. Clearly, with $\lambda = 1$ and then $v_H = 1$ we are back to (8) and the Kaldorian solution. This is not the end of the story, however, since (11) may be made even simpler. Observe, indeed, that v_H may be written as:

⁶ In a very interesting paper, Lunghini and Bianchi (2004) use the metaphor of the banker as a landlord

$$v_H = \frac{K - V_b}{K}$$

Now, banks' wealth is given by the stock of outstanding loans minus the stock of deposits. The latter, in turn, is by definition equal to households' wealth less households' holdings of corporate bonds. Therefore

$$v_H = \frac{K - L + M}{K} = \frac{K - L + (V_H - \frac{B}{i})}{K} = 1 - l + v_H - \frac{B}{iK}$$

As a result, we must have

$$\frac{B}{iK} = (1 - l) \tag{12}$$

a somewhat obvious result in our framework. Indeed, (12) simply says that the share of corporate bonds in the hands of households over the capital stock is equal to the share of the capital stock which is not financed by banks. What is not financed by banks is financed by households, and vice versa. Now, (12) may be formulated as

$$\frac{B}{iV_h} \frac{V_h}{K} = (1 - l)$$

$$\frac{B}{iV_h} v_H = (1 - l) \tag{13}$$

where (B/iV_h) is the fraction of households' wealth held in the form of corporate bonds. Needless to say, this fraction is an expression of households' liquidity preference. The stronger their liquidity preference, the lower that fraction. Abstracting from the so-called "transaction" demand for money (which here is not relevant at all), calling μ a pure liquidity preference parameter (the higher μ the weaker liquidity preference, i.e. the higher the share of their wealth households want to keep in the form of bonds for any given interest rate) and $\mu_1 > 0$ the sensitivity of bonds demand to the interest rate, in principle one could write

$$\frac{B}{iV_h} = \mu + \mu_1 i$$

This standard formulation – incorporating the idea that liquidity preference weakens with higher interest rates – is even too much for our purposes. Sure, we could safely adopt this formulation without affecting our results but, in light of the fact that we are developing our argument under the assumption of a fixed interest rate, it is more convenient to represent liquidity preference simply through a fixed parameter:

$$\frac{B}{iV_h} = \mu \leq 1$$

This way, (13) may be written as

$$l = 1 - \mu v_H \tag{14}$$

The idea underlying (14) is simple. If households' liquidity preference increases (μ goes down), banks *must* fund a higher fraction of capital accumulation to keep the interest rate constant at the level of their own willing. Now, just plug (14) into (11) to get

$$c = \alpha[u - i(1 - \lambda)] + [\beta + \alpha i \mu(1 - \lambda)]v_H \quad (15)$$

which is the final formulation of our consumption function. Some observations are worth doing. First, variations in the share of national wealth in the hands of households, v_H , produce both a direct and an indirect effect on consumption. The former (β) was simply postulated, whereas the latter is more interesting. *Ceteris paribus*, a higher v_H is necessarily associated to a lower i (see (14)) and this, for any given rhythm of accumulation, increases households' income and then consumption. Another message conveyed by (15) is that a lower liquidity preference (higher μ) increases consumption. The reason is the same – households' income grows since the share of investments financed by banks falls. Finally, as expected, aggregate consumption falls when the interest rate goes up: in this case, indeed, a higher proportion of non-financial firms' profits (that are *fully* distributed to households) are transferred to banks, and the latter do not distribute the totality of their profits to households.

Solving the model formed by (7), (10) and (15) is extremely easy. The short-run solution is:

$$u = \frac{\gamma + [\beta + \alpha i \mu(1 - \lambda)]v_H - \alpha i(1 - \lambda)}{1 - \alpha - \delta} \quad (16)$$

$$g = \frac{\gamma(1 - \alpha) + \delta\{[\beta + \alpha i \mu(1 - \lambda)]v_H - \alpha i(1 - \lambda)\}}{1 - \alpha - \delta} \quad (17)$$

The standard short-run stability condition for this kind of Keynesian model is $1 - \alpha - \delta > 0$, and we will assume it holds. In this case, it is easy to check that if the equilibrium utilization rate u is positive, i.e.

$$\gamma + [\beta + \alpha i \mu(1 - \lambda)]v_H > \alpha i(1 - \lambda) \quad (18)$$

the equilibrium growth rate g will be positive as well⁷. The short-run equilibrium of this economy is easily represented in a quite standard "Keynesian-cross" diagram (figure 1).

[FIGURE 1 ABOUT HERE]

In the right-hand side of the diagram, the aggregate demand curve, AD, is obtained as the sum of (15) and (10). Its slope is $1/(\alpha + \delta) > 1$ (the stability condition) and its intercept on the horizontal axis is negative since (18) is assumed to hold. The 45-degrees curve represents the equilibrium condition (7). The intersection between the two curves determines the equilibrium utilization rate (equation (16)) and this, in turn, determines in the left-hand side of the diagram – where the "Growth" curve is nothing but the investment function (10) – the equilibrium growth rate (equation (17)). The temporary (short run) nature of the equilibrium

⁷ Indeed, the condition ensuring that $g > 0$ is $\frac{\gamma(1 - \alpha)}{\delta} + [\beta + \alpha i \mu(1 - \lambda)]v_H > \alpha i(1 - \lambda)$.

depicted in Figure 1 should be clear. Indeed, the solutions for u and g (and, for that matters, c as well) clearly depend on the value taken by the state variable $v_H = V_H/K$ (the reader may check that with $\lambda = 1$ and then $v_H = 1$, we would move back to the same solution associated to the Kaldorian view), which determines the position of the AD schedule⁸. We then have to concentrate on the evolution over time of v_H to understand the dynamics of this model economy.

Before doing so, however, some comparative statics might be useful. First, observe that a reduction of the share of distributed banks' profits, λ , is clearly contractionary: the AD schedule shifts to the left and both u and g go down. When banks are forced (or want themselves) to retain more profits and strengthen their balance sheets to reassure the general public and have their liabilities accepted as means of payment, households' current income falls and so do aggregate demand and output. Second, a higher fraction of national wealth in the hands of households, v_H , increases the level of activity and makes the economy grow faster: the AD schedule moves to the right because, as we saw, aggregate consumption responds positively to households' accumulated wealth⁹. Third, and more importantly, a rise in households' liquidity preference (lower μ) shifts the AD curve upward and both the level of activity and the growth rate fall. In this case, a higher proportion of capital accumulation is to be funded by the banking system and this is enough to lower households' income and consumption. Even in a framework where money is endogenous and banks assumed to be able to fix the interest rate at some target level, liquidity preference continues to be a crucial parameter in the determination of the macro equilibrium. All what we need to defend the traditional Keynesian role of liquidity preference in a framework of endogenous money is to recognize that banks must retain some profits to accumulate own funds. Will this important result hold in the medium run as well?

4.2 *The medium run*

To answer this question, let us have a look to the dynamics of v_H . By definition, it must be:

$$\dot{v}_H = \frac{\dot{V}_H}{K} - v_H g \quad (19)$$

Since we are abstracting from capital gains, households' savings are the sole determinant of the evolution of their wealth, i.e.:

$$\dot{V}_H = Y - (1 - \lambda)iL - C \quad (20)$$

Putting (20) into (19) and using (7), we get:

⁸ The vertical intercept of the AD schedule is $-\{\gamma + [\beta + \alpha i \mu (1 - \lambda)]v_H - \alpha i (1 - \lambda) / (\alpha + \delta)\}$.

⁹ Richer households make the economy grow faster, but it is also true that growth makes households richer. This mechanism of cumulative causation is a source of potential instability for the economy we are dealing with and, as we shall see, it will be important to impose some parametric restrictions to guarantee the (local) stability of its steady state.

$$\dot{v}_H = (1 - v_H)g - (1 - \lambda)il \quad (21)$$

Using (14), the law of motion for v_H becomes:

$$\dot{v}_H = (1 - v_H)g - (1 - \lambda)(1 - \mu v_H)i \quad (22)$$

By plugging the short run equilibrium value of the growth rate (equation (17)) into (22), we finally get:

$$\dot{v}_H = av_H^2 + bv_H + d \quad (23)$$

where

$$a = -\frac{\delta[\beta + \alpha i \mu(1 - \lambda)]}{1 - \alpha - \delta}$$

$$b = \frac{\delta\beta - \gamma(1 - \alpha) + (1 - \lambda)i[\mu(1 - \alpha)(1 - \delta) + \delta\alpha]}{1 - \alpha - \delta} = \frac{\delta\beta + (1 - \lambda)i\delta\alpha + (1 - \alpha)[i\mu(1 - \lambda)(1 - \delta) - \gamma]}{1 - \alpha - \delta}$$

$$d = \frac{(1 - \alpha)[\gamma - i(1 - \lambda)(1 - \delta)]}{1 - \alpha - \delta}$$

Equation (23) is a second-degree differential equation. From a geometric point of view, it is an inverted parabola (note that $a < 0$) with roots v_{HL} and v_{HR} , where $v_{HL}, v_{HR} = \frac{-b \pm \sqrt{b^2 - 4ad}}{2a}$. The specific configuration taken by equation (23), and consequently by the two solutions ensuring $\dot{v}_H = 0$, depends on the actual constellation of the parameters defining the coefficients “ a ”, “ b ” and “ d ”. Given the negative value of coefficient “ a ”, different scenarios emerge according to the combination of negative/positive values of “ b ” and “ d ”. In order to be economically meaningful, the roots of equation (23) must be real and included in the range between 0 and 1, i.e., $0 \leq v_{HL}, v_{HR} \leq 1$. So, let us assume the determinant $\Delta = (b^2 - 4ad)$. Figures 2.a, 2.b and 2.c below portray three scenarios, S.1, S.2 and S.3, associated to the relevant parametric configurations. In scenario S.1, $d > 0$ and $b < 0$; in scenario S.2, $d > 0$ and $b > 0$; finally, in scenario S.3 we have $d < 0$ and $b > 0$. Let us have a look to all of them.

Figure 2.a describes the scenario S.1, where $\gamma > i(1 - \lambda)(1 - \delta)$ and hence $d > 0$: the vertical intercept of the parabola is positive. On top of this, “ b ” is assumed to be negative. By observing that “ b ” represents the slope of (23) for $v_H = 0$, this assumption implies that v_{HL} is certainly negative whilst v_{HR} is positive and potentially relevant. To verify that v_{HR} is positive but lower than 1, just combine equation (22) with the “borderline” condition $v_H = v_H^{MAX} = 1$. This way, one can easily see that $\dot{v}_H|_{v_H=v_H^{MAX}} = -(1 - \lambda)(1 - \mu)i < 0$, and this clearly implies that v_{HR} lies to the left of the borderline value v_H^{MAX} and is certainly lower than 1. In the end, with “ d ” positive and “ b ” negative, only one acceptable and *stable* medium-run equilibrium v_{HR} exists.

A qualitatively similar case is described in Figure 2.b, where $d > 0$ and $b > 0$ characterize scenario S.2. In this case, the intersection between (23) and the vertical axis is again positive but takes place on the upward sloping arm of the parabola. As before, only the “right-side”

medium run steady state value v_{HR} is economically acceptable (the same demonstration used for scenario S.1 also applies to this case).

A third potentially relevant scenario is S.3, with $d < 0$ and $b > 0$. Provided that the determinant Δ is positive, this scenario will feature two different steady states in the positive quadrant ($v_H > 0$). Nonetheless, we still have to ascertain whether any or both equilibria fall into the acceptable range of values running from 0 to 1. In order to do so, we first need to remind that, from (22), $v'_H|_{v_H=v_H^{MAX}}$ is always negative. Given this, we must check whether the intersection between (23) and the vertical boundary $v_H = 1$ occurs on the upward- or downward-sloping arm of the parabola. In the first case, we would have two positive equilibria, but both would fall outside the acceptable range of values (0,1). No meaningful equilibria would exist. In the second case, instead, both equilibria would fall within the range (0,1) and be economically acceptable.

We can distinguish these two cases from each other by taking the derivative of (23) with respect to v_H , and then calculating its value at $v_H = 1$. Straightforward calculations show that $(\partial v'_H / \partial v_H)_{v_H=v_H^{MAX}} = 2a + b$. As a consequence, we will have $(\partial v'_H / \partial v_H)_{v_H=v_H^{MAX}} > 0$ if $-b/2a > 1$. Alternatively, should $-b/2a$ be lower than 1, we will get $(\partial v'_H / \partial v_H)_{v_H=v_H^{MAX}} < 0$. Figure 2.c portrays this last case since, as we know, it is the only one featuring meaningful equilibria. Observe that, as usual, v_{HL} is unstable and v_{HR} is stable. Interestingly enough, scenario S.3 features a sort of “depression trap” on the left of the unstable equilibrium v_{HL} . Indeed, should the economy end up in that region, households would rush away from bonds’ holding to store all their wealth in the form of liquid assets (i.e., banks’ deposits). Financial markets would permanently shrink and eventually collapse. According to the economic mechanisms described before, this may force the economy into a long-lasting depression, i.e., a sizable contraction in both capital accumulation and economic activity.

[FIGURES 2.a - 2.c ABOUT HERE]

Once identified the three different scenarios that are relevant for our medium run analysis, we can study the effects of changes in the liquidity preference on the medium run equilibria of our economy. Consistently with the medium-run dynamics portrayed in Figures 2.a – 2.c, it makes sense to focus our analysis on the unique stable equilibrium of this economy, v_{HR} . More specifically, we want to analyze how v_{HR} varies when μ changes. To do so, it is important to remark that, given $a < 0$ and $\Delta > 0$, we have:

$$v_{HL} = \frac{-b + \sqrt{b^2 - 4ad}}{2a} \quad \text{and} \quad v_{HR} = \frac{-b - \sqrt{b^2 - 4ad}}{2a}$$

By taking the derivative of v_{HR} with respect to μ , we get:

$$\partial v_{HR} / \partial \mu = \frac{-\left(\frac{\partial b}{\partial \mu} + \frac{1}{2}\Delta \frac{\partial \Delta}{\partial \mu}\right)2a + 2\frac{\partial a}{\partial \mu}(b + \Delta^{1/2})}{4a^2} \quad (24)$$

where:

$$\frac{\partial a}{\partial \mu} = -\frac{(1-\lambda)\alpha\delta i}{1-\alpha-\delta} < 0$$

$$\frac{\partial b}{\partial \mu} = \frac{(1-\alpha)(1-\lambda)(1-\delta)i}{1-\alpha-\delta} > 0$$

$$\frac{\partial \Delta}{\partial \mu} = 2b \frac{\partial b}{\partial \mu} - 4d \frac{\partial a}{\partial \mu} = \frac{2(1-\lambda)i}{1-\alpha-\delta} [(1-\alpha)(1-\delta)b + 2d\alpha\delta] \geq 0$$

Equation (24) does not provide a clear-cut finding as to the effect of a change in households' liquidity preference on the medium run stable equilibrium of the economy. This effect might be either positive or negative depending on the specific parametrical constellation characterizing the economic system. More specifically, the role of the accelerator " δ " turns out to be fundamental in the determination of the final result. The economic rationale is the following. In the short run, a lower (higher) level of households' liquidity preference (i.e., a higher (lower) value of parameter μ) induces households to store a higher (lower) share of their wealth in the form of firms' bonds. This, in turn, boosts (depresses) capital accumulation by raising (lowering) households' income, consumption and, hence, capacity utilization. Should capital accumulation respond very strongly to even a small increase in aggregate demand and capacity utilization (i.e., should " δ " be high), firms' financial needs might grow more rapidly than the funds that households are more generously making available. In such a case and keeping in mind that banks aim at keeping the interest rate at some constant level, a *larger* share of firms' productive investment will have to be financed by banks' loans rather than households' bonds. Perhaps paradoxically, the economy may then eventually end up in a medium run equilibrium where the share of national wealth (the economy's capital stock) held by households, v_{HR} , is lower than it was before the reduction of liquidity preference. Under these circumstances, a lower liquidity preference would reduce capacity utilization and slow economic growth.

In general, as we just saw, attaching a well-defined sign to the effect of a change in μ over v_{HR} is not possible. However, we can identify some specific parametric conditions that ensure $(\partial v_{HR}/\partial \mu)$ to be positive in the three scenarios portrayed in Figures 2.a – 2.c. The analysis referred to scenario S.1 ($d > 0$; $b < 0$) is rather simple. Indeed, it suffices to say that whilst an increase in μ does not have any effect on " d ", it certainly increases " b ", i.e. the slope of (23) in correspondence with its intersection with the vertical axis. Given $b < 0$, the parabola rotates around point " d " and its downward-sloping arm gets flatter. Its new intersection with the horizontal axis, albeit remaining lower than 1, will lie to the right of the previous one. We can then conclude that, under the conditions of scenario S.1, the derivative $(\partial v_{HR}/\partial \mu)$ is certainly positive. A less pronounced liquidity preference (a higher μ) raises v_{HR} and boosts the economy even in the medium run.

The analysis associated to scenario S.2 ($d > 0$; $b > 0$) is slightly more complicated. Provided that (24) does not provide a clear outcome as to the sign of $\partial v_{HR}/\partial \mu$, we can better understand the medium run effects of changes in liquidity preference by analyzing how μ affects the shape of the parabola portrayed in Figure 2.b. Three points are worth stressing.

First, given $(\partial b/\partial\mu) > 0$, when μ increases, the parabola in Figure 2.b rotates counterclockwise around point “ d ”. Second, after some algebra, it is possible to verify that the vertex $M(M_x, M_y)$ of the parabola moves upward when μ increases. If we take the derivative of the ordinate M_y of point M in Figure 2.b with respect to μ , the condition for $(\partial M_y/\partial\mu) > 0$ reads:

$$\frac{(1-\alpha-\delta)+\alpha\delta}{\alpha\delta} > \frac{1}{2} \left\{ \frac{\delta\beta+(1-\lambda)i\delta\alpha}{\delta\beta+(1-\lambda)i\delta\alpha\mu} + \frac{[i\mu(1-\lambda)(1-\delta)-\gamma]}{\delta\beta+(1-\lambda)i\delta\alpha\mu} \right\} \quad (25)$$

It can be easily verified that condition (25) always holds in the case described by the scenario S.2, since $\frac{(1-\alpha-\delta)+\alpha\delta}{\alpha\delta}$ is certainly higher than 1, whilst $\frac{1}{2} \frac{\delta\beta+(1-\lambda)i\delta\alpha}{\delta\beta+(1-\lambda)i\delta\alpha\mu} < 1$ (whatever the value of μ) and $\frac{[i\mu(1-\lambda)(1-\delta)-\gamma]}{\delta\beta+(1-\lambda)i\delta\alpha\mu} < 0$.

A similar conclusion applies to the abscissa M_x of the vertex M . The derivative of M_x with respect to μ is positive when

$$\frac{(1-\alpha-\delta)+\alpha\delta}{\alpha\delta} > \frac{\delta\beta+(1-\lambda)i\delta\alpha}{\delta\beta+(1-\lambda)i\delta\alpha\mu} + \frac{[i\mu(1-\lambda)(1-\delta)-\gamma]}{\delta\beta+(1-\lambda)i\delta\alpha\mu} \quad (26)$$

The first term on the right-hand side of (26) is now higher than 1. Nevertheless, for reasonably high values of γ such that $d > 0$ and $[i\mu(1-\lambda)(1-\delta)-\gamma] < 0$, condition (26) is likely to hold. In scenario S.2, an increase in μ is likely to move the vertex of the parabola represented in Figure 2.b to the right.

As a final point, observe that $(\partial v_H|_{v_H=1}/\partial\mu) = (1-\lambda)i > 0$: accordingly, the intersection between (23) and the upper bound $v_H = 1$ takes place for a higher (i.e., less negative) value of v_H . Figure 3 puts these three points together and shows how, in scenario S.2, an increase in μ (a lower preference for liquidity) moves the parabola associated to equation (23) up and to the right (see the red dashed parabola). Therefore, the new stable medium-run equilibrium point will lie to the right of the old one and $(\partial v_{HR}/\partial\mu) > 0$.

[FIGURE 3 ABOUT HERE]

The analysis related to scenario S.3 is quite similar. Parameter “ d ” is now negative and this makes the medium run effect of a reduction in liquidity preference even harder to determine. However, provided that $\mu < \frac{\gamma}{i(1-\lambda)(1-\delta)}$, so that $[i(1-\lambda)(1-\delta)-\gamma] > 0$, $d < 0$ but $[i\mu(1-\lambda)(1-\delta)-\gamma] < 0$, an increase in μ still induces the parabola portrayed in Figure 2.c to rotate counterclockwise. Whilst both $(\partial b/\partial\mu)$ and $(\partial v_H|_{v_H=1}/\partial\mu)$ remain positive, the above parametric condition ensures that the vertex of the parabola moves upward and to the right, as shown in Figure 4. Interestingly enough, whilst the left-hand side unstable equilibrium v_{HL} moves further to the left, the right-hand side stable equilibrium v_{HR} moves further to the right.

[FIGURE 4 ABOUT HERE]

5. The role of liquidity preference in a financialized economy: concluding remarks and extensions

The central theoretical result of our analysis is that, even in a world of endogenous money where the banking system behave in a fully “horizontal” manner, liquidity preference of the general public, far from “ceasing to be of any importance”, plays a crucial role in shaping the performance of the economy both in the short and the medium run. Assuming that “being a banker is costly” (i.e. some positive portion of banks’ profit cannot be distributed) is more than enough to reconstitute liquidity preference such a key role. We also showed, however, that the inclusion of capital gains and/or the assumption of imperfect substitutability between bonds and bank loans (from the borrower’s perspective) would produce the same outcome.

Our model also suggests that financial turbulences and sudden increases in liquidity preference (i.e., sharp reductions in μ) may cause long-lasting negative effects on economic performances. From figures 2.a to 2.c, this is represented by a leftward shift of the medium run steady state value of v_{HR} , implying a slowdown in capital accumulation and a lower level of economic activity. Even the more so in scenario S.3, where a run to liquidity could shift the unstable equilibrium v_{HL} to the right and then widen the “depression area” to the left of v_{HL} itself. In other words, a financial crash and a sharp flight to liquidity could eventually cause an expanding economy perhaps at the beginning of the transition from v_{HL} to v_{HR} to find itself irretrievably stuck in such a “depression trap”.

Our medium-run analysis seems to suggest that having households eager to invest in financial markets, perhaps with a higher propensity to risk and a lower liquidity preference, might be beneficial for capital accumulation and economic dynamics. Could we then take this result as an indication of the potential virtues of “money manager” or “financial” capitalism (Wray, 2011)? Are households’ active participation to financial markets, as intermediated by buoyant institutional investors (Whalen, 2017), and the rising share of capital income over national income (Power *et al.*, 2003; Piketty, 2014) good news for the whole economy? The answer is no, at least for two good reasons. First, in this paper, we do not make any comparison between different types of capitalism, say *paternalistic* or *industrial capitalism* (Minsky, 1986; Hudson, 2010) of the “golden age” on the one side, and the current *financial capitalism* on the other. What we claim is that in a financialized system where financial markets gain increasing relevance in affecting the behavior of the economy, it is vital to ensure that financial markets keep on working smoothly, and that they are not hit by major waves of panic and sudden runs to liquidity. In a way, our paper suggests that, in the present state of capitalism, saving Wall Street from financial shocks is fundamental to avoid Main Street to collapse. We could well interpret this result as an additional sign of financial markets’ “take-over” of the real economy (Storm, 2018). Secondly, our model provides a simplified representation of reality that, for the sake of analytical tractability, does not take on board several aspects of modern financialized economies. In this paper, for instance, we do not

endogenize the heightened instability and vulnerability of the current type of capitalism to financial crises, with the ensuing consequences in terms of (non-financial) firms' animal spirits and willingness to invest. More than that, in the present paper we do not pay attention to distributional issues. Indeed, here we do not model the increasing level of income inequality and wealth concentration that has accompanied the development of modern financialized economies (Botta *et al.*, 2019), as well as the increasing debt burden on the shoulders of low- and middle-income households. It goes without saying that these aspects could well contribute to provide a far less enthusiastic image of the alleged virtues of a financialized economy.

All these remarks are potentially interesting extensions of our model and could it make it richer and more *nuancé*. None of them, however, would alter the central theoretical message we want to reiterate once again. The original insight of Maynard Keynes is to be rescued: liquidity preference and financial markets matter, and money endogeneity, not even in its radical, horizontalist declination, does *not* mean that we are allowed to think of the banking system as the unconstrained *deus ex-machina* of the economy we live in.

References

- Asensio, A. 2017. "Insights on endogenous money and the liquidity preference theory of interest", *Journal of Post-Keynesian Economics*, vol.40 (3), 327 – 348.
- Bertocco G., and A. Kalajzic. 2014. "*The liquidity preference theory: A critical analysis*", University of Insubria department of economics working paper no.1402.
- Bertocco, G., and A. Kalajzic. 2018. "The zero lower bound and the asymmetric efficacy of monetary policy: A view from the history of economic ideas", *Italian Economic Journal*, vol.4 (3), 549 – 566.
- Bibow, J. 2009. "*Keynes on Monetary Policy, Finance and Uncertainty: Liquidity Preference Theory and the Global Financial Crisis*", London: Routledge.
- Botta, A., Caverzasi, E., Russo, A., Gallegati, M., and J.E. Stiglitz. 2020. "Inequality and finance in a rent economy", forthcoming in *Journal of Economic Behavior and Organization*.
- Carlin, W., and D. Soskice. 2014. "*Macroeconomics: Institutions, Instability and the Financial System*", Oxford: Oxford University Press.
- Dafemos, Y. 2012. "Liquidity preference, uncertainty, and recession in a stock-flow consistent model", *Journal of Post-Keynesian Economics*, vol.34 (4), 749 – 776.
- Dow, S. C. 1997. "Endogenous Money". In: G. C. Harcourt G.C., and P.A. Riach (ed.) "*A 'Second Edition' of The General Theory*", 43 – 55. London and New York: Routledge
- Fontana, G. and M. Setterfield. 2009. "A simple (and teachable) macroeconomic model with endogenous money". In: Fontana, G. and M. Setterfield. (eds.). "*Macroeconomic Theory and Macroeconomic Pedagogy*", 144 – 168, London: Palgrave Macmillan.
- Hudson, M. 2010. "*The Transition from Industrial Capitalism to a Financialized Bubble Economy*", Levy Economics Institute of Bard College Working Paper no.627.
- Kaldor N. 1985. "How monetarism failed", *Challenge*, vol.28 (2), 4 – 13.

- Lavoie, M. 2006. "Endogenous money: Accommodationist". In: Arestis, P., and M. Sawyer (eds). *"Handbook of Alternative Monetary Economics"*, 17 – 34, Cheltenham, UK: Edward Elgar.
- Lavoie, M. 2009. "Taming the new consensus: Hysteresis and some other Post-Keynesian amendments". In: Fontana, G., and M. Setterfield (eds.). *"Macroeconomic Theory and Macroeconomic Pedagogy"*, 191 – 213, London: Palgrave Macmillan.
- Lavoie, M. and S., Reissl. 2019. "Further insights on endogenous money and the liquidity preference theory of interest", *Journal of Post-Keynesian Economics*, vol.42 (4), 503 – 526.
- Lunghini, G., and C. Bianchi. 2004. "The Monetary Circuit and Income Distribution: Bankers as Landlords?" In: Arena, R., and N. Salvadori (eds.). *"Monet, Credit and the Role of the State: Essays in Honour of Augusti Graziani"*, 152 – 74. Hants, UK: Ashgate.
- Mehrling, P. 2020. "Payment vs. funding: The law of reflux for today" Institute of New Economic Thinking working paper series no.113, freely downloadable from the Institute of New Economic Thinking (INET) website: https://www.ineteconomics.org/uploads/papers/WP_113-Mehrling-Payment-vs-Funding.pdf.
- Minsky, P.H. 1986. *"Stabilizing and Unstable Economy"*, Yale University Press.
- Moore, B.1988. "The Endogenous Money Supply", *Journal of Post Keynesian Economics*, vol.10 (3), 372 – 385.
- Oeiro J.L., Fernando de Paula, L., and J.P. Heringer Machado. 2020. *"Liquidity preference, capital accumulation and investment financing: Fernando Carvalho's contributions to the post-Keynesian paradigm"*, PKES working paper no.2007.
- Palley, T. 1994. "Competing views of the money supply: Theory and evidence", *Metroeconomica*, vol.45 (1), 67 – 88.
- Palley, T. 2013. "Horizontalists, verticalists, and structuralists: the theory of endogenous money reassessed", *Review of Keynesian Economics*, vol.1 (4), 406 – 424.
- Palley, T. 2017. "The theory of endogenous money and the LM schedule: prelude to a reconstruction of IS-LM", *Revista de Economia Politica*, vol.37 (1), 3 – 22.
- Piketty, T. 2014. *"Capital in the Twenty-First Century"*, Cambridge (MA) and London (UK): Harvard University Press.
- Power, D., Epstein, G., and M. Abrena. 2003. *"Trends in The Rentier Income Share in OECD Countries, 1960 – 200"*, PERI Working Paper no.58a.
- Storm, S. 2018. *"Financial Markets Have Taken over the Economy. To Prevent Another Crisis, They Must Be Brought to Heel"*, freely downloadable from the Institute of New Economic Thinking (INET) website: <https://www.ineteconomics.org/perspectives/blog/financial-markets-have-taken-over-the-economy-to-stop-the-next-crisis-they-must-be-brought-to-heel>.
- Whalen, J.C. 2017. *"Understanding Financialization: Standing on the Shoulders of Minsky"*, Levy Economics Institute of Bard College Working Paper no.892.
- Wray, R. 2009. "The Rise and Fall of Money Manager Capitalism: A Minskyan Approach", *Cambridge Journal of Economics*, vol.33 (4), 807 – 828.

Tables

Table 1 – The balance sheet of the economy

	HOUSEHOLDS	FIRMS	BANKS	TOT
Deposits (Money)	M		$-M$	0
Loans		$-L$	L	0
Bonds	B/i_b	$-B/i_b$		0
Capital		K		K
Net worth	V_h	$V_F (= 0)$	V_b	$V_h + V_F + V_b = K$

Table 2 – Flow of funds of the economy

	HOUSEHOLDS	FIRMS		BANKS		TOT
		c/a	k/a	c/a	k/a	
Flows						
Consumption	$-C$	C				0
Investment		I	$-I$			0
[memo: GDP]	$GDP = Y = C + I = i_L L + B + W + \Pi$					
Bank Inter.		$-i_L L$		$i_L L$		0
Bonds Inter.	B	$-B$				0
Wages	W	$-W$				0
Firms Profits	Π	$-\Pi$				0
Banks Profits	$\lambda i_L L$			$-i_L L$	$(1-\lambda)i_L L$	0
FoFs						
Money	$-\dot{M}$				\dot{M}	0
Bonds	$-\dot{B}/i_B$		\dot{B}/i_B			0
Loans			\dot{L}		$-\dot{L}$	0
TOT	0	0	0	0	0	0
[memo: capital gains]	$-\hat{i}_b(B/i_B)$	0	$\hat{i}_b(B/i_B)$	0	0	0

Figures

Figure 1 – The short-run equilibrium

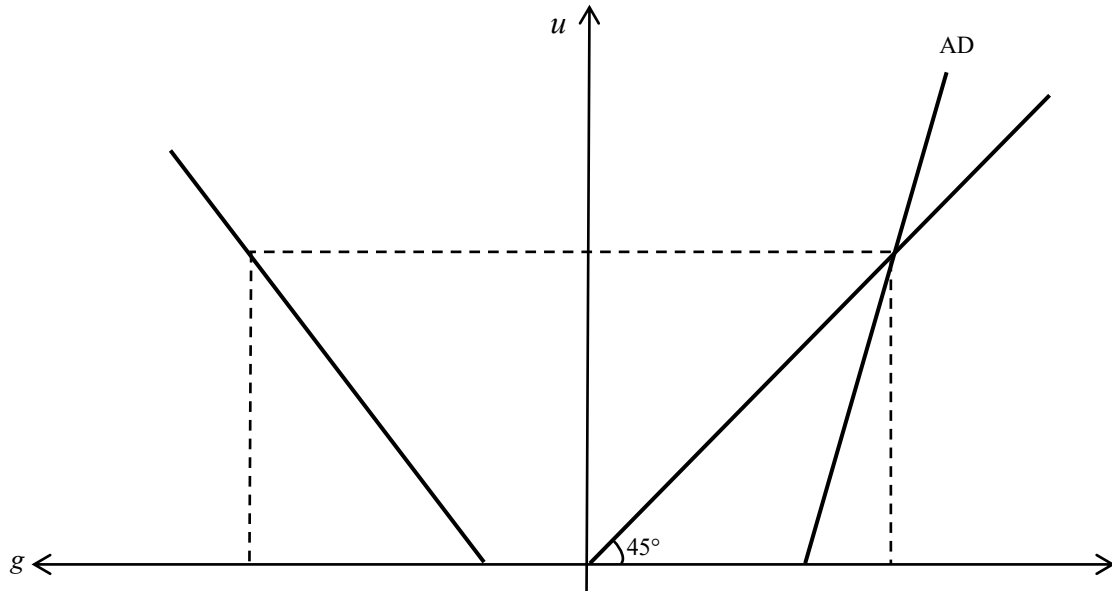

Figure 2.a: Medium-run equilibrium under parametric scenario S.1 ($d > 0$; $b < 0$)

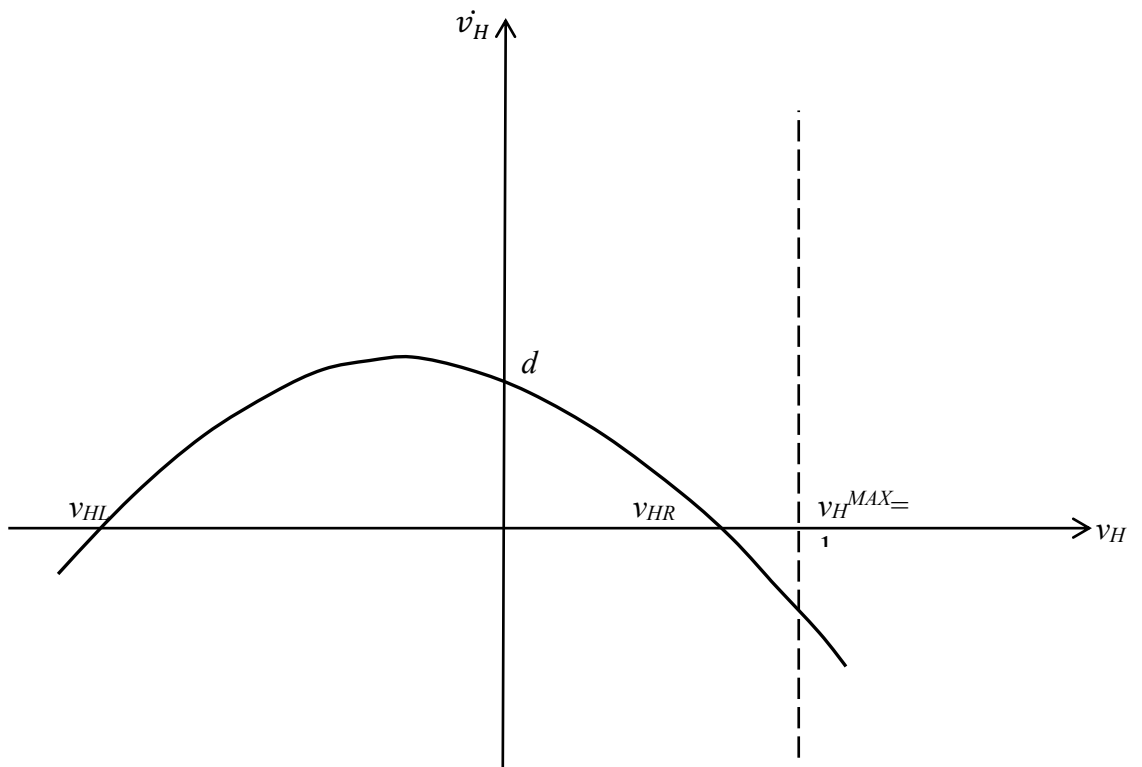

Figure 2.b: Medium-run equilibrium under parametric scenario S.2 ($d > 0$; $b > 0$)

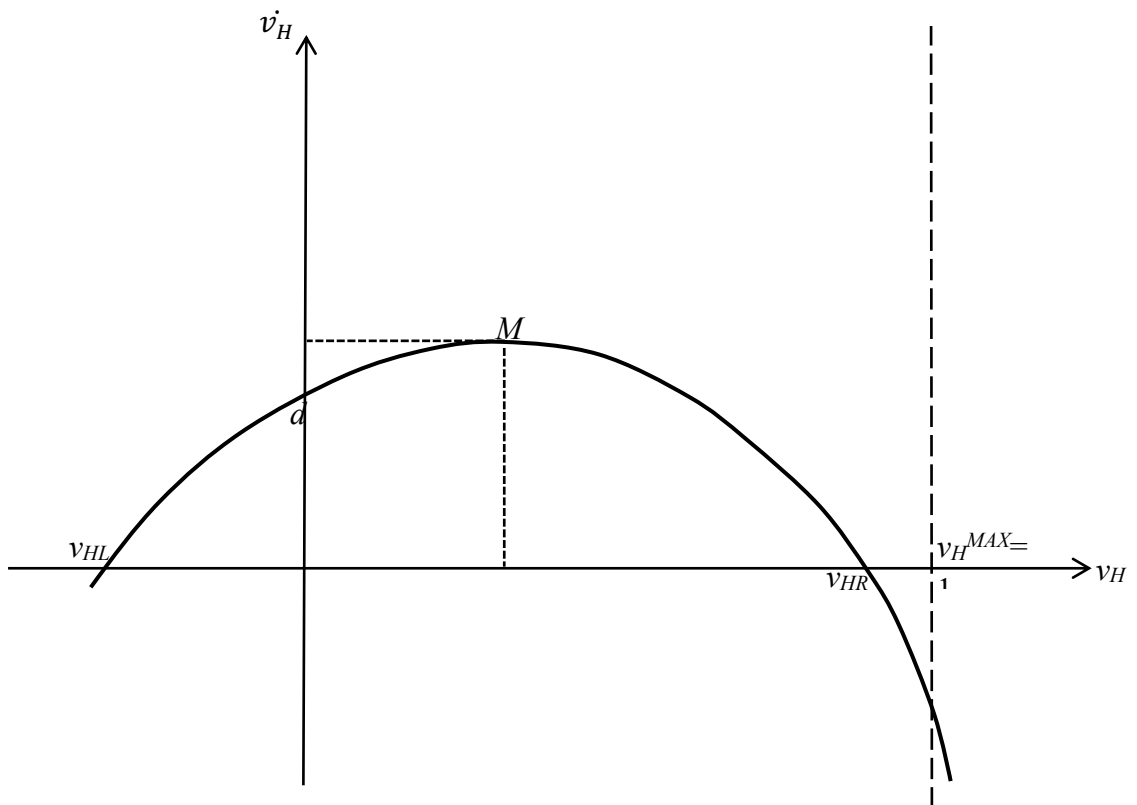

Figure 2.c – Medium-run equilibria under parametric scenario S.3 ($d < 0$; $b > 0$) and $(-b/2a) <$

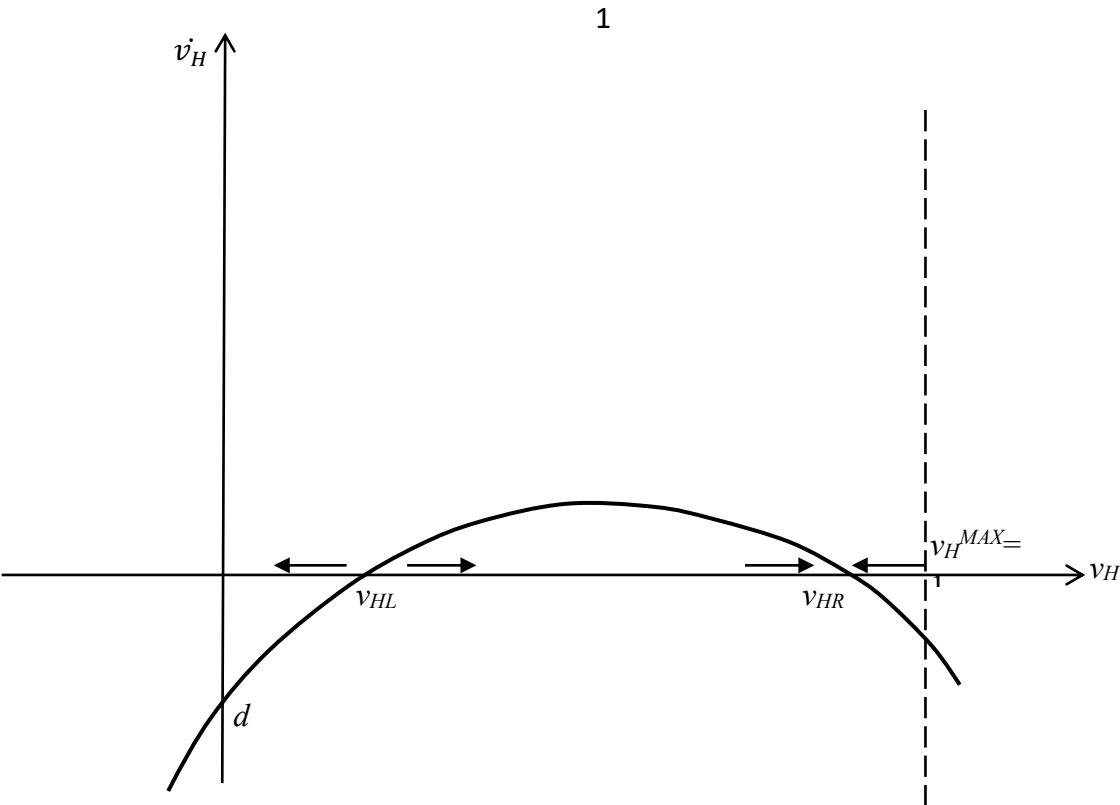

Figure 3 – Medium-run effects of a lower preference for liquidity (a higher value of μ) in scenario S.2

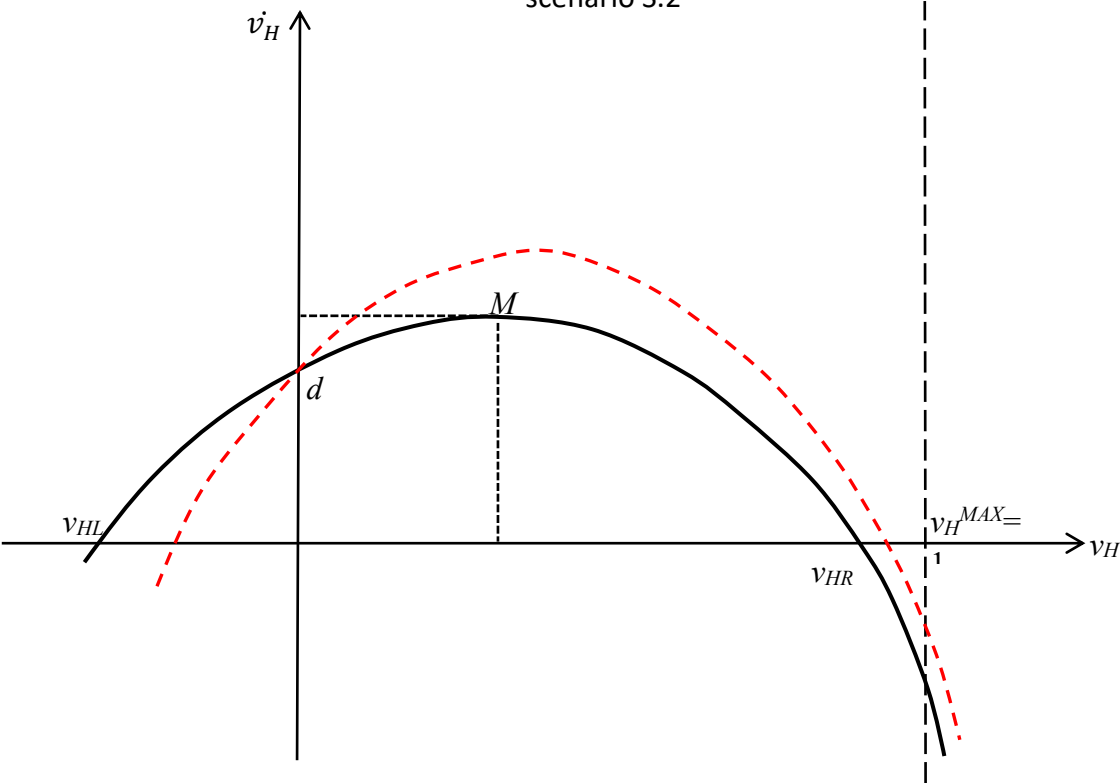
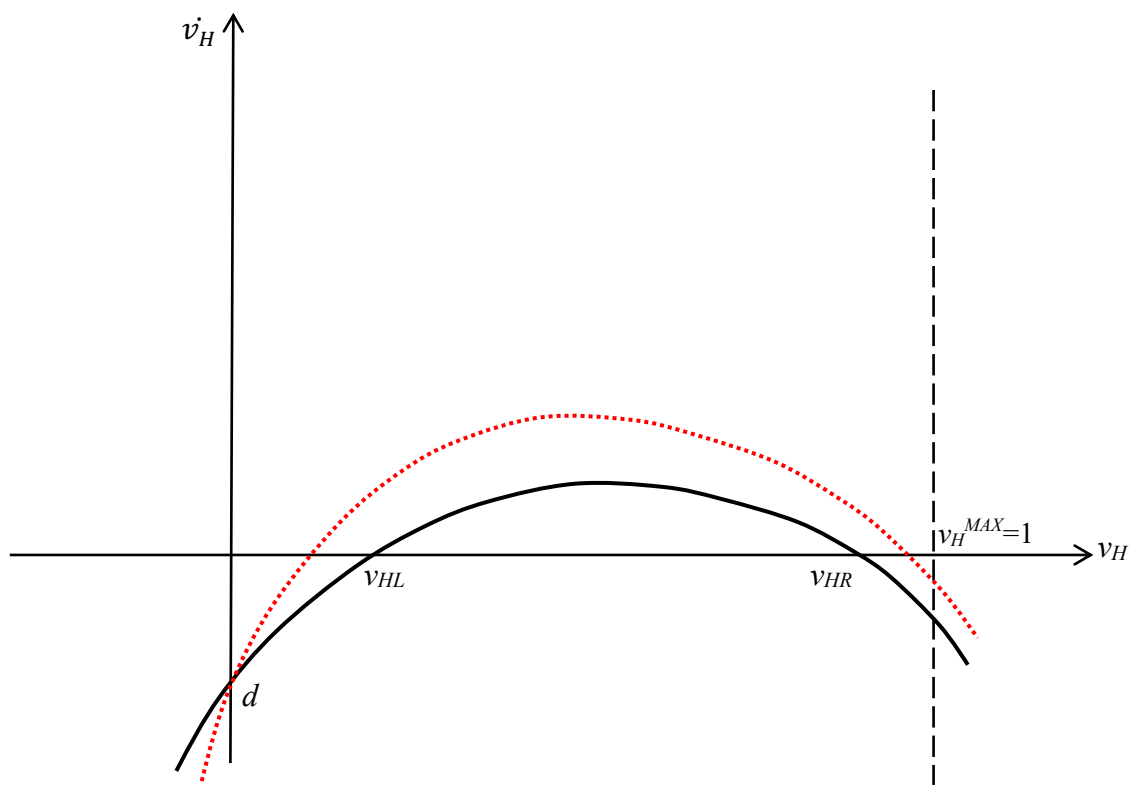

Figure 4 – Medium-run effects of a lower preference for liquidity (a higher value of μ) in scenario S.3 assuming $\mu < \frac{\gamma}{i(1-\lambda)(1-\delta)}$



Appendix 1: The Evolution of Banks' Wealth

Equation (4) in the text says that banks' wealth evolves according to

$$\dot{V}_b = \dot{L} - \dot{M} = (1 - \lambda)i_L L$$

The economic intuition behind this relation is extremely simple: banks' own capital increases with retained profits. Yet, it might be worth clarifying the "making" of banks' balance sheet to facilitate a deeper understanding. The balance sheet we are talking about is

ASSETS		LIABILITIES	
Loans	L	Deposits	M
		Own funds	V_b
Total	L	Total	L

and one could be tempted to think that banks' loans are funded out of deposits and own funds. Loans (assets) are the "use of funds" and deposits and banks' own funds (liabilities) are the "source of funds". This way of thinking, however, is misleading. In the concrete world of endogenous money we live in, loans are *not* funded out of deposits and own funds. This simple fact, however, does *not* imply that collecting deposits and accumulating own funds is not important for single banks. It is more than important: it is vital.

Think of the beginning of the world, a time 0 where "the" bank (which may be thought of as the consolidation of commercial banks and the central bank, but here this is not really relevant) makes an overall loan of 100 to some firms by creating *ex-nihilo* and crediting a deposit in favor of each of them:

ASSETS		LIABILITIES	
Loans	100	Deposits of firms	100
		Own funds	0
Total	100	Total	100

Firms will use this money to fund some investment project. The Keynesian multiplier will operate and generate an aggregate income of, say, 500 (meaning that we are postulating an average propensity to consume of 80%). Firms' gross profits are, say, 100 and wages amount to 400. We can safely assume that firms' gross profits are fully distributed to capitalists' households. In the aggregate and for the time being, then, households disposable income is 500 (the same as GDP). The average propensity to save is 20% and, once again for the sake of the argument, we can assume there are no securities around and people may only hold their

savings in a bank account. All the above implies that, for the time being, the bank's balance sheet look like

ASSETS		LIABILITIES	
Loans	100	Deposits households	100
		Own funds	0
Total	100	Total	100

This is not the end of the story, however. Firms must pay an interest to banks. If the interest rate is 10%, the interest bill is 10. Firms' owners (i.e. some households) will make this payment to the bank and, needless to say, this is nothing but banks' profit:

ASSETS		LIABILITIES	
Loans	100	Deposits households	$100 - 10 = 90$
		Own funds	$0 + 10 = 10$
Total	100	Total	100

At this point, the bank decides to distribute a fraction (say, 50%) of its profit to its owners (other households, of course) and, at last, we can see the final configuration of the bank's balance sheet:

ASSETS		LIABILITIES	
Loans	100	Deposits households	$100 - 10 + 5 = 95$
		Own funds	$0 + 10 - 5 = 5$
Total	100	Total	100

The reader may very easily check that this last table is nothing but a different way of writing down equation (4): the growth of banks' wealth is fully determined by their undistributed profits (and of course this is exactly what happens with non-financial firms too).